

MCS BV290 Indirect Heater

Highly Efficient Devices, Large Volumes of Instant Heat

Indirect oil heaters are highly efficient devices that provide large volume of 100% clean, dry and fume free warm air. They are best for places with limited ventilation like shops, event's tents, food preparation areas or exhibition halls. They can be used with flexible hoses that make the warm air be spread around easily.



Specifications

Power	Btu/h	259000
Combustible		Diesel/Kerosene
Net Weight	lb	222
Gross Weight	lb	271
Ø Fan	in	19,7
Ø Chimney Flue	in	6
Performance	%	84
Airflow	cfm	1950
Fuel Consumption	gal	2,0
Tank Capacity	gal	27.7
Autonomy	h	12
Tension	V	110-120
Frequency	Hz	60
Rated Current	A	11.4
Electric Power	kW	1.5
Noise Level	dBa	78
Pump Pressure	PSI	174

Packaging

Packaging Dimensions	in	66 x 30 x 47
Effective Dimensions	in	63 x 28 x 37
Pieces for Pallet	n°	1
Pieces Full Truck	n°	50

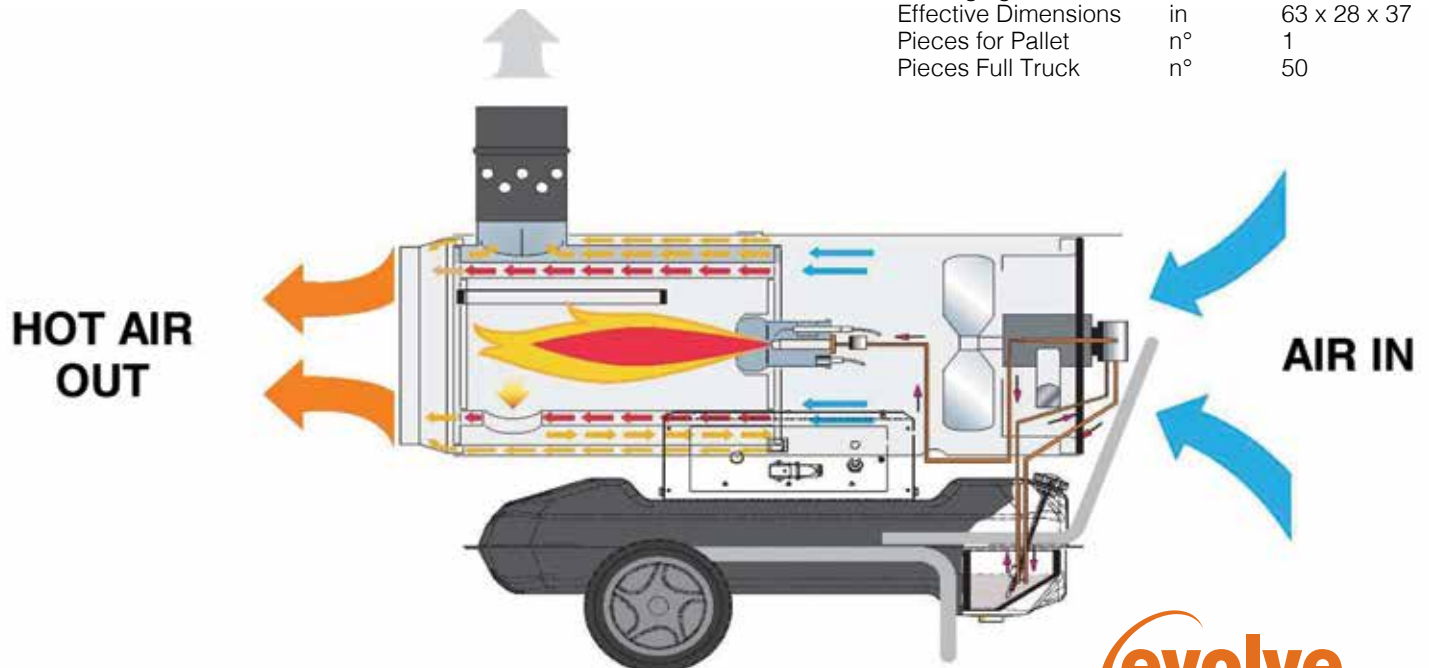

Components

Pump	Danfoss BFP - rotary with element filter
Nozzle	1,5 GPH 80°S
Flame Control	Electronic board and separately transformer
Igniter	Bifilar electrodes
Fuel Filter	In line da 230 mesh
Overheat thermostat	Yes / N.C. until at 90 °C
Motor	Asynchronous, monophase, with thermal protection, Anticlockwise rotation, 1600 rpm
Tank	Material steel sheetmetal
Room Thermostat	Predisposition for connection of room thermostat

Accessories

Ambient Thermostat	Thermostat TH5
Hose flexible	Yes
Adaptor ring kit	Yes
Filter Pre-heating	Predisposition for connection the pre-heating filter

Wiring

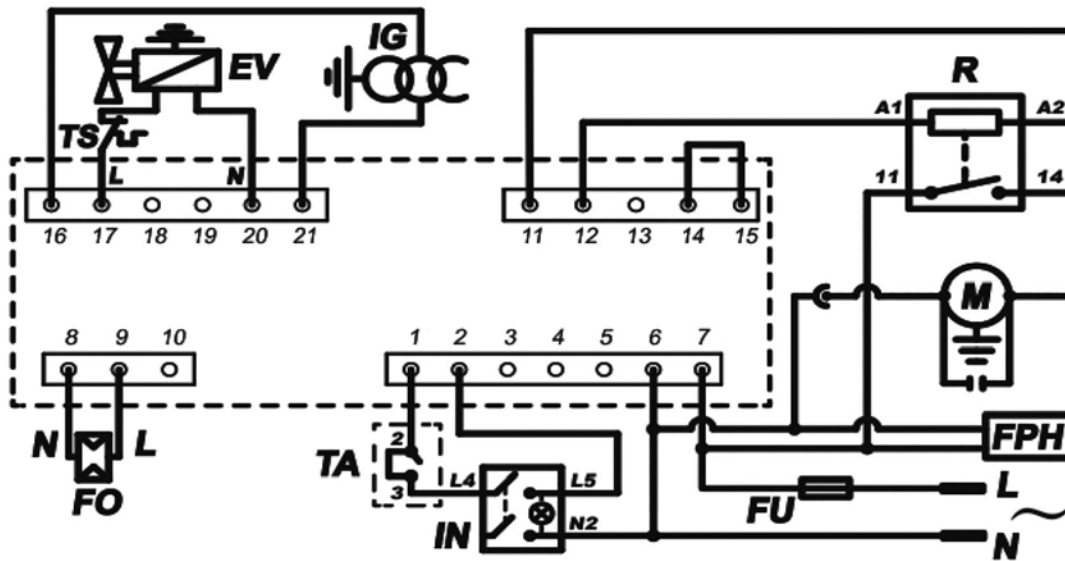

FO: Photoresistance
 TA: Ambient Thermost
 IG: Transformer
 FPH: Pre-heating Filter
 M: Motor
 R: Relay
 IN: Switch
 FU: Fuse
 EV: Electric Valve
 TS: Overheat Thermost
 N: Neutral
 L: Line

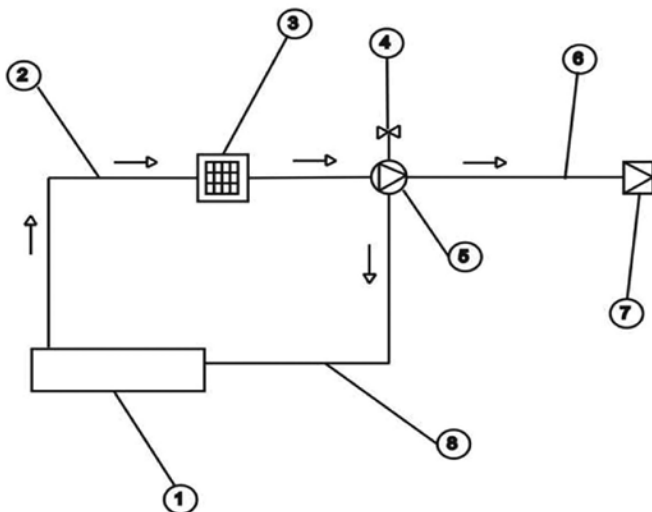

Fuel

- 1 Tank
- 2 Fuel Pipe Intake
- 3 Fuel Filter
- 4 Electrovalve
- 5 Pump
- 6 Fuel Pipe Supply
- 7 Nozzle
- 8 Fuel Return Pipe

evolve
emergency
 PREPAREDNESS

7 Industrial Way, Salem, NH 03079-2817
 Tel: 1-888-315-9007
www.evolvecorp.com